

FTTH 8 Core Outdoor Fiber Distribution Terminal Box

Terminal Box is made of high-quality ABS material. It is widely applied to the splicing and distributing variable optical cables.

Features

- Special double D box body design, light weight, compact structure.
- Rotary Internal structure,super-stratum for splicing and distributing, substratum for cable arrangement.
- Cable input&output is mechanical sealing
- Protection grade reach IP65.
- Box body use ABS material.



Dimension

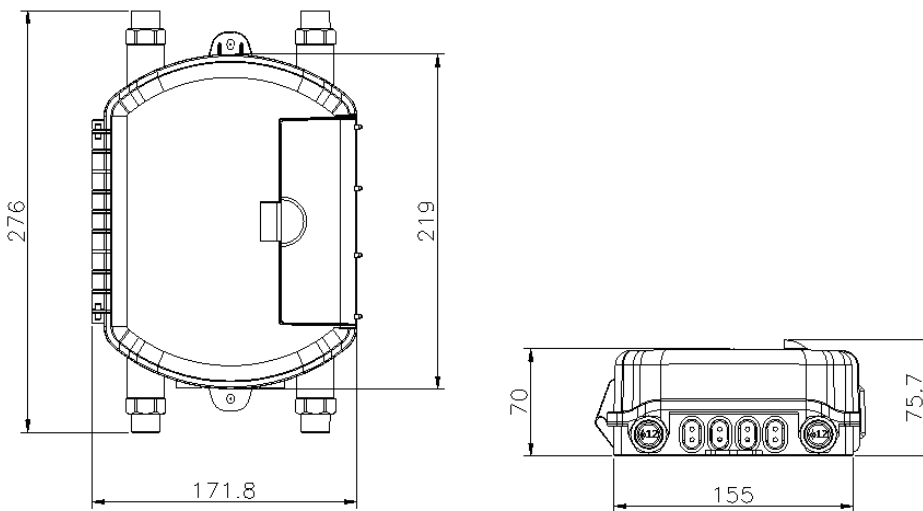

Cable Arrangement

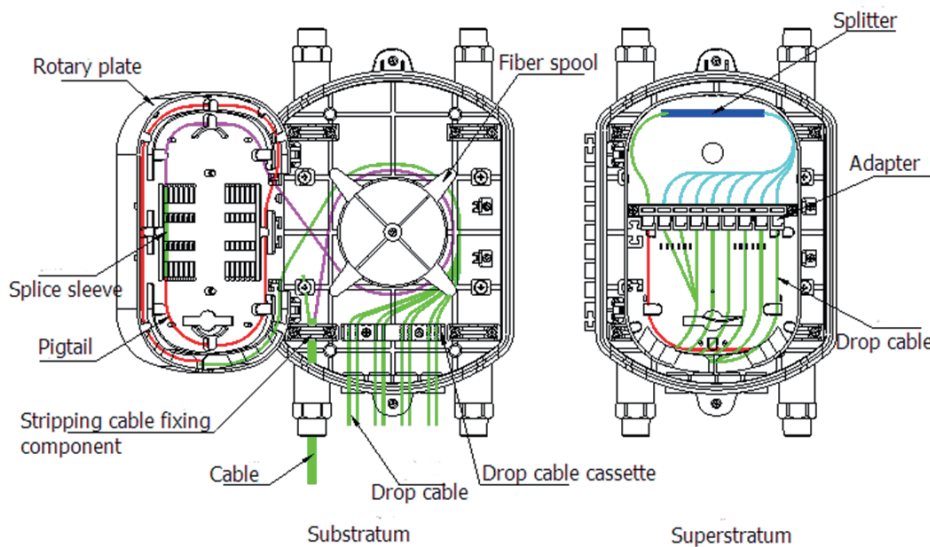

Product Model	Fiber Count	Splitter	Splice tray Model & Qty	Cable port diamter
Insertion Loss	/	1*8 PLC (steel tube type)	/	2pcs Ø8mm, 2pcs Ø12mm, 8pcs Ø3mm